

50HZ

Performance Curves

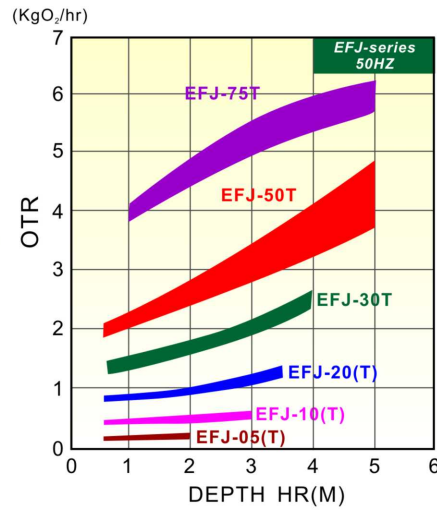
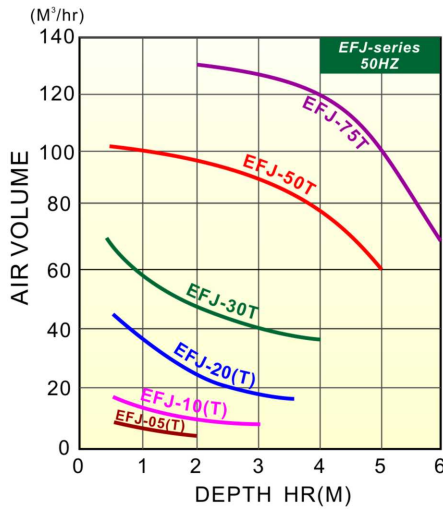

Performance Tables

Model	HP	Rated performance			Suit aeration Tank		
		Air (M³/hr)	OTR (KgO₂/hr)	HR (M)	L (M)	W (M)	H (M)
EFJ-05(T)	0.5	5	0.12~0.23	1.5	2.0	1.8	2.0
EFJ-10(T)	1	10	0.3~0.5	2.0	3.0	2.5	3.0
EFJ-20(T)	2	22	0.9~1.1	2.5	4.0	3.5	3.5
EFJ-30T	3	40	1.9~2.2	3.0	5.0	4.5	4.0
EFJ-50T	5	85	3.0~3.8	3.5	6.0	5.0	5.0
EFJ-75T	7.5	120	4.2~5.2	4.0	7.0	6.0	6.0

Remarks: ● (T): Three phase motor

Dimensions

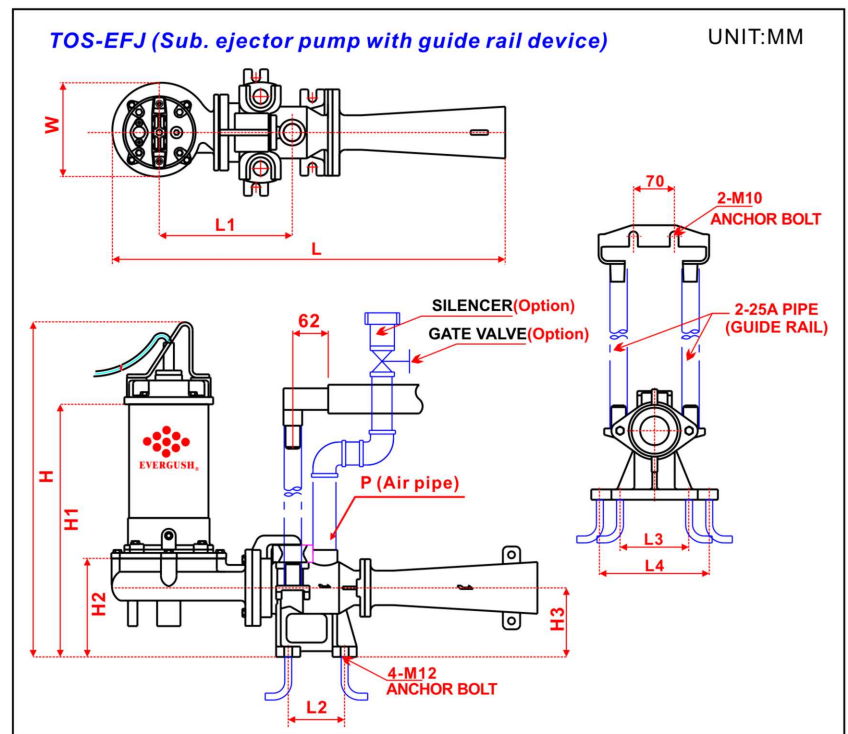
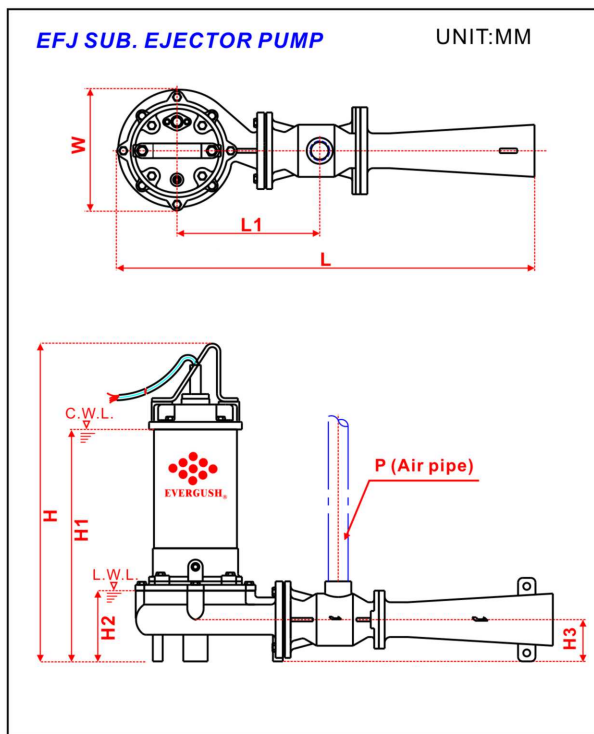

EFJ Dimension Tables

Model	HP	Dimensions (MM)								Net Weight Kg
		L	L1	W	H	H1	H2	H3	P	
EFJ-05(T)	0.5	649	197	163	417	304	120	72	25A	23
EFJ-10(T)	1	649	197	163	471	347	120	72	25A	31
EFJ-20(T)	2	719	246	208	548	400	122	72	40A	40
EFJ-30T	3	719	246	208	568	420	122	72	40A	42
EFJ-50T	5	769	290	227	633	468	160	92	50A	68
EFJ-75T	7.5	769	290	227	673	508	160	92	50A	74

Remarks: ● (T): Three phase motor.

TOS-EFJ Dimension Tables

Model	HP	Dimensions (MM)											Net Weight Kg
		L	L1	L2	L3	L4	W	H	H1	H2	H3	P	
TOS-EFJ-05(T)	0.5	683	231	98	120	190	163	465	352	168	120	25A	33
TOS-EFJ-10(T)	1	683	231	98	120	190	163	519	395	168	120	25A	41
TOS-EFJ-20(T)	2	753	280	98	120	190	208	596	448	170	120	40A	50
TOS-EFJ-30T	3	753	280	98	120	190	208	616	468	170	120	40A	52
TOS-EFJ-50T	5	983	480	160	150	---	227	749	579	280	200	50A	82
TOS-EFJ-75T	7.5	983	480	160	150	---	227	789	619	280	200	50A	88

Remarks: ● (T): Three phase motor.